

SolarShower 300 Fountain Pump with Battery Back-Up

This instruction contains important information for using the product for the first time. Please keep this instruction for later reference. They should always accompany the product in the Event of transfer a new user.

1 OVERVIEW

- 1.1 The solar pump is designed for fountain, pond or outdoor use. In order for the solar pump to operate, the solar panel needs to be in direct sunlight.
- 1.2 This solar pump is equipped with battery pack and can be switched on and off by a touch switch on the control housing. In evening, four built-in white LEDs will give light automatically to enhance the beauty scene of the water jet.

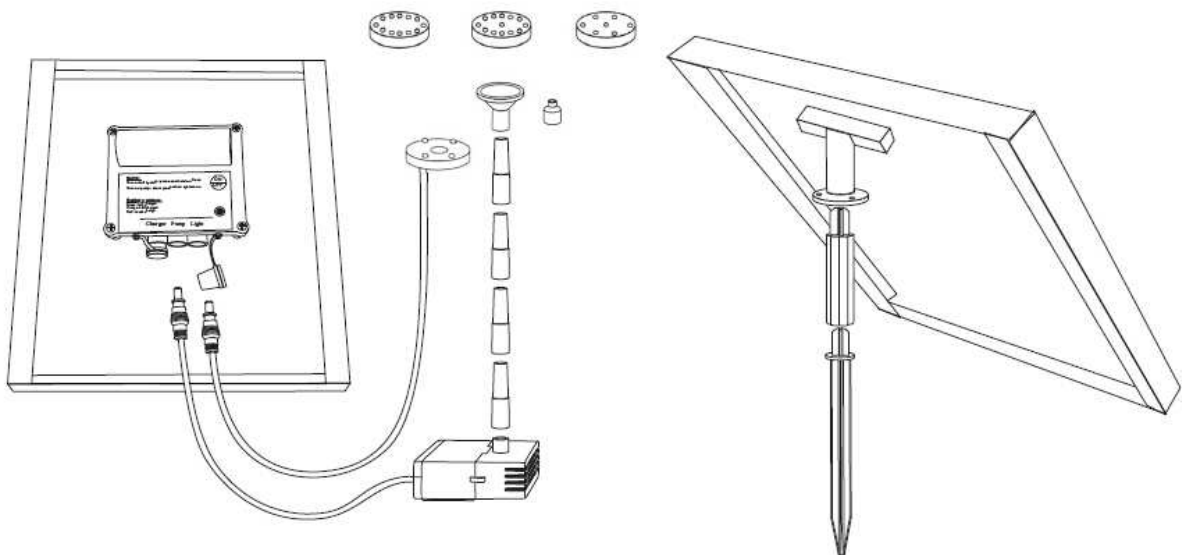

2 ASSEMBLING AND USING YOUR PRODUCT

- 2.1 Unpack all components carefully.
- 2.2 Place the pump underwater and make sure that, it is fully immersed in water. In case the pump tube is too far from the surface of water, you can raise the pump by using stones or brick underlay.
- 2.3 Connect fountain heads and LED light as required;
- 2.4 Adjust the water jet as needed
- 2.5 Connect the pump cable to the socket of the control housing on the rear side of the solar panel;
- 2.6 Connect the LED light (optional) cable to the socket of the control housing;
- 2.7 The solar pump is now ready to use.

3 CAUTION

- 3.1 Do not strike the solar panel
- 3.2 Do not let the pump run dry for long time
- 3.3 Do not lift the pump by the power cord
- 3.4 Operate in freshwater only

4 OPERATING INSTRUCTIONS

Turn on the pump: short press the ON/OFF position to turn on the pump, the pump will run certain hours (ref to battery status) and turn to solar mode automatically. The pump will operate automatically next day in direct sunlight.

Charge the battery: press and hold on 3 seconds to Turn OFF the pump and charge the full solar energy to battery during day time, turn on the pump when you need it (on demand).

Battery status:





Green: battery is full charged. Pump will run around 4-6 hours.

Orange: battery is half charged. Pump will run around 2-4 hours.

Red: battery needs charges. Pump will run less than 1 hour.

Note: The indicator light is blinking when pump on, the indicator light is solid when pump off.

Pump performance in different weather condition:

Weather	1. Pump on 2. Charge extra solar energy to battery	1. Pump off 2. Charge full solar energy to battery
	Solar runs the pump and charges the battery. Pump performance is maintained when the clouds pass. Pump runs on fully half an hour longer into the evening.	Battery should be fully charged in 1day.
	Solar runs the pump and supplies extra energy to the battery. Performance is maintained when the clouds pass. Pump will only run a shorter period of time into the evening.	Battery will take 2 to 3 days to fully charge.
	Pump will only run when there is sufficient power from the battery. Little or no battery charging occurs so pump performance is not maintained.	Battery will take several days to fully charge.
	No solar power is available, pump will not run and battery will not charge.	Battery will not charge.

If the pump stop running when cloudy or night, and you want to force the pump running for certain hours, short press to turn on the pump, the pump will run certain hours until battery flat.

Note: LED lights will only function at night.

5 CLEANING AND MAINTENANCE

Pump: If, after a period of time, the pump starts to lose power or stops working check for the build up of sediment, scale or dirt in the filter. Remove the pump cover and the impeller cover. Clean them and the filter by fresh water.

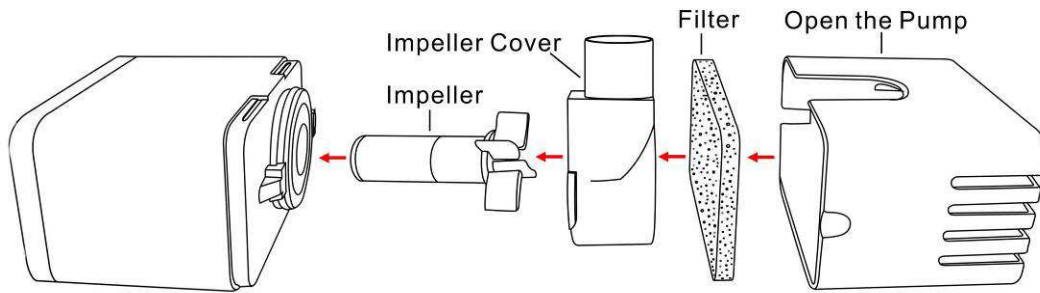

Solar panel: The panel should be cleaned periodically with a soft tissue. Regular cleaning of the panel is advised to maintain optimum conversion of the sun's energy into direct current.

6 FUNCTIONALITY PROBLEMS

6.1 Pump does not operate even though the solar module is in full sunlight.

- No connection to the solar module – check connection to the solar module.
- Impeller is blocked – To clean the pump, remove the front plate and the impeller. Use a small brush or stream of water to remove any debris.

6.2 Pump does operate but there is no water running through the fountainhead check for the build up of sediment or scale in the tubes or the filter- clean the tubes and the filter.

7 TECHNICAL DATA

Solar Panel:	3 W
Operation Voltage:	9V DC
Water Flow Max.	300LPH
Water lift Max.:	1M
Water Projection Height	Max. 0.6M
LED Light (optional)	4 LED white light
Cable Length	5M
Lithium Battery	7.4V-2000mAH

8 WARRANTY INFORMATION

This product is guaranteed for a period of 12 months from the date of purchase for material or manufacturing defects. The guarantee covers the substitution of defective parts.. If your pondXpert pump fails please take it back to the retail outlet from where it was purchased. You will be required to take your receipt/proof of purchase with you. This does not affect your statutory rights.

PondXpert, A3 Bentley Avenue, Billingham, TS23 4BU, UK

01642 370898 www.pondxpert.co.uk

Your appliance contains valuable materials which can be recovered or recycled. Leave it at a local civic waste collection point

