

 **pondXpert**



**UK  
CA** 

**ElectroAir Compact**  
**600 / 1200 / 1800 / 2400 / 3600**

# PondXpert ElectroAir Compact Operating Instructions



**Persons who have not read and understood the operating instructions should not use the air pump!**

This device is not intended for use by persons or children with impaired physical, sensory or intellectual impairments, or if lacking in experience and or know-how, unless they are under supervision or have been trained in the use of the device by a person responsible for their safety.

Children should be supervised to ensure that they do not play with the device.

## Application

These air pumps are designed for aerating ponds, filters and aquariums.

The pump is not suitable for use in water.

It may not be used in swimming pools!

For technical information on the air pump, see the nameplate or the table on page 5.



## Safety instructions

- Warning! This air pump may only be used if the electrical system meets relevant statutory requirements. If in doubt, consult a qualified electrician.
- The mains voltage and current type must match the information on the nameplate.

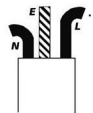

The wires in the mains electrical lead are coloured in accordance with the following code:

BLUE – Neutral (marked with an “N” in most terminal connections)

BROWN – LIVE (marked with an “L” in most terminal connections)

GREEN/YELLOW – EARTH (marked “E” or  in most terminal connections)

1st January 2005 revised Building Regulations for England and Wales

Installing this product in the garden is classified as 'notifiable'. The Regulations now require you to tell your local authority building control department that you intend to install this product before installation. Your local authority will let you know how you can get your installation approved.

The termination to the mains supply should be permanent, inside a dry weatherproof enclosure through a double pole switched fused spur with a minimum contact gap of 3mm—(disconnected) to BS 3676 – and fitted with a 3 or 5 amp fuse. Exposed cable runs should be sensibly positioned, and protected if necessary by armoured conduit. A 10mA or 30mA Residual Current Circuit Breaker (RCD) MUST be fitted to the mains supply

- Place the power outlet in a moisture-free area, at least 2m from the water's edge. (see figure 1, page 5.)
- Locate the pump in a position so that it cannot fall into the water.
- Warning! If placed on a smooth base, the vibrations may cause the pump to “walk” during operation.
- Place the air pump above water level (see Figure 1, page 5.)
- The air pump may also be installed outdoors! (IP44)
- Important: do not use if the air pump, power cord or plug is damaged. Bring it back to your dealer.
- Do not suspend or transport the air pump by the power line (cable).
- Keep the plug and air pump dry. To prevent water from running from the cord or air line to the plug or air pump, suspend the cord in a U-shape (see figure 2, page 5.)
- When working on the air pump or in the water, always unplug the pump from the electrical outlet to cut off the power supply.
- Do not use the pump when there are people in the water.
- The air pump should only be used above water level.
- Place in a well-ventilated area to prevent overheating.
- Make sure that the pump is not in direct sunlight.
- Protect the air pump from freezing.

# PondXpert ElectroAir Compact Operating Instructions



**Operating instructions** (Figure 1, page 5.)

**Important: Do not immerse the air pump in water, protect it against flooding. Place the pump on a firm surface above the water surface.**

- Place the pump in an area that is protected against flooding.
- Make sure that the pump draws clean and pure air.
- Place the air pump on a flat level surface above the water level.
- Secure the air pump to prevent it from walking.
- Connect the rubber hose coupler to the pump outlet and secure it with the supplied hose clamp.
- Slide the other hose clamp over the rubber hose coupler.
- Connect the air distributor to the other side of the rubber hose coupler and secure it with the hose clamp.
- Connect the air stones to the air diffuser with air hoses.
- Place the air stones in the water.
- If the air pump is properly installed and connected, it can be switched on by plugging in the power plug.



**Maintenance** (Figures page 5.)

Regular maintenance:

- Turn off the air pump by unplugging the power cord from the electrical outlet.
- Regularly clean the foam filter (4): Unscrew the two screws (2) of the cover (3) and remove the cover (3) of the casing (5). First, remove the caps (1) from the screws before the screws can be loosened.
- If the foam filter (4) is dirty, take it out and clean it with air or replace it for a new foam filter (4).
- After cleaning, place everything back, fix the cover (3) with the two screws (2).
- If the air pump is properly installed and connected, it can be switched on by plugging in the power plug.

To ensure a long life span and problem-free operation, we recommend that you check the pump regularly for air capacity reduction by checking whether the air stones are producing enough air bubbles.

- If the air capacity has decreased, check the air stones and replace, if necessary. Clogged air stones will lead to low air pressure output in the pump and reduce the life of the diaphragms and pump.
- Switch off the air pump by unplugging the power cord from the electrical outlet before doing any maintenance.

If replacement of the air stones does not improve the air capacity, check the air pump and replace the membranes.

- Turn off the air pump by unplugging the power cord from the electrical outlet.
- Unscrew the four screws (6) of the pump housing (5) and remove the pump housing (5) of the bottom plate (23).
- Remove the four screws from the motor flap (9) and remove the motor cap (9). (Note that the four nuts (18) remain at their place).
- Lose one of the two motors (11) by removing the 2 screws (12).

# PondXpert ElectroAir Compact Operating Instructions

- Unscrew the 4 screws (8) from the membrane housing on both sides of the motor cap (9).
- Take the membrane unit (13) from the motor cap (9) and replace it with a new one.
- Place the new membrane unit (13) in the motor cap (9) and tighten the eight screws (8).
- Place the motor (11) back and secure it with the two screws (12).
- Place the motor cap (9) back (note the two o-rings (14) and tighten the screws (note the nuts (18)).
- Place the pump housing (5) back and fasten it with the four screws (6).
- If the air pump is properly installed and connected, it can be switched on by plugging in the power plug.



## In the winter

- Protect the air pump from frost.
- Do not allow the air pump to draw hot air, as this will cause condensation in the air hose to the pond or filter and the hose may likely clog up or freeze in the winter.



## Removal and storage of waste

All household electrical appliances must be removed in accordance with EU directives. The product may not be disposed of with the normal household waste, but should be collected separately.

You are personally responsible for bringing the device to a designated landfill site. It must be dismantled and processed in an environment-friendly manner.

More information on local landfill sites can be obtained from the municipality in which you live.

## Limited Warranty

This product is guaranteed for a period of 12 months from the date of purchase for material or manufacturing defects. The guarantee covers the substitution of defective parts.

However, the guarantee is considered null and void in the case of improper use, improper handling or negligence on the part of the buyer. If your pondXpert air pump fails please take it back to the retail outlet from where it was purchased. You will be required to take your receipt/proof of purchase with you.

This does not affect your statutory rights.

PondXpert  
A3 Bentley Avenue  
Billingham  
TS23 4BU  
UK

01642 370898      [www.pondxpert.co.uk](http://www.pondxpert.co.uk)

# ElectroAir Compact Air Pump Specifications

600	1200	1800	2400	3600
12 V ~ / 50 Hz	12 V ~ / 50 Hz	12 V ~ / 50 Hz	12 V ~ / 50 Hz	12 V ~ / 50 Hz
P 10W	P 15W	P 25W	P 30W	P 35W
Q max. 600 l/h	Q max. 1200 l/h	Q max. 1800 l/h	Q max. 2400 l/h	Q max. 3600 l/h
0,2 Bar	0,2 Bar	0,25 Bar	0,3 Bar	0,3 Bar
IPX4	IPX4	IPX4	IPX4	IPX4
1.5m	1.5m	2.0m	2.5m	2.5m

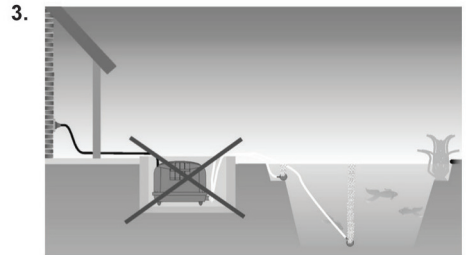
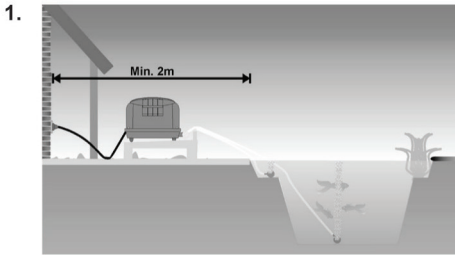
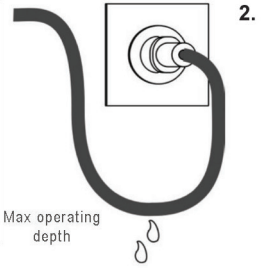

Spare parts  
600, 1200, 1800, 2400

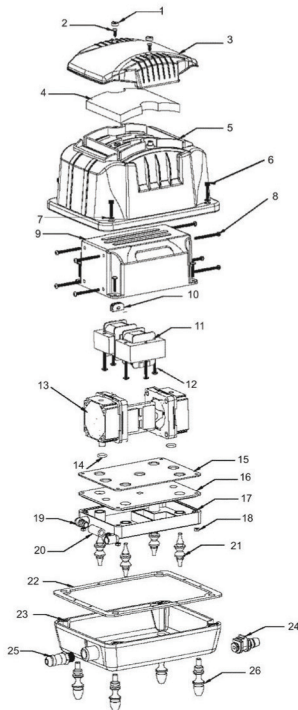

Spare parts  
3600

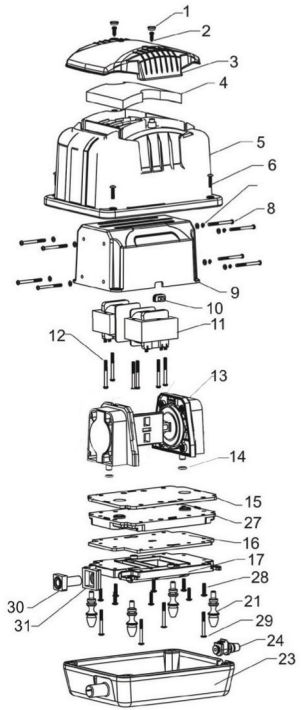



**PondXpert**  
**A3 Bentley Avenue**  
**Billingham**  
**TS23 4BU**  
**UK 01642 370898**  
**[www.pondxpert.co.uk](http://www.pondxpert.co.uk)**