



SolarShower 25W Extension Panel for 3000 Pump Instruction Manual

1. OVERVIEW

- 1.1. The solar panel is designed for outdoor use, to expand the PXSOL3000 power. In order to make the pump work, the solar panel needs to be placed in the sun with facing the sunlight.
- 1.2. The performance of the pump depends on the sunlit intensity and the position of the solar module.

2. ASSEMBLING

- 2.1. Unpack all components carefully
- 2.2. Unroll the cable.
- 2.3. Connect the two pieces of the solar panel by plug-in the connect cable, adjust the panel bracket to the right angle.
- 2.4. The set is now ready to operate.

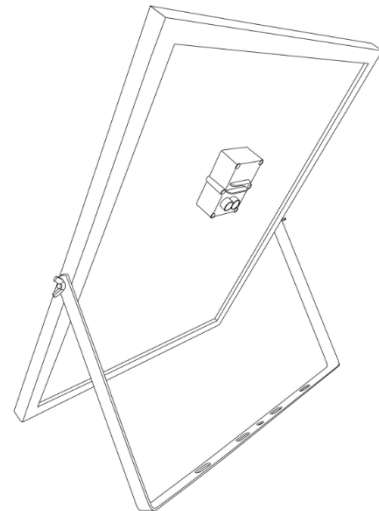
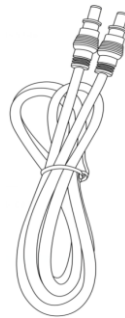
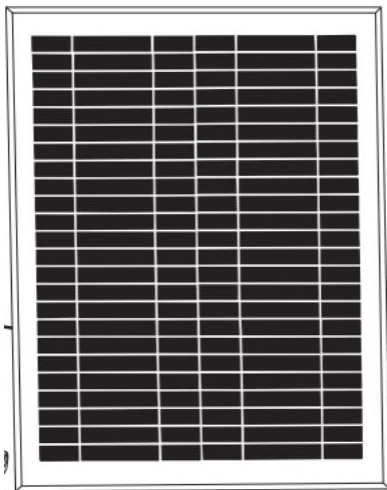

3. CAUTIONS

- 3.1. Any altering of the product itself or changing of the components is forbidden.
- 3.2. Do not strike the solar panel.

4. CLEANING AND MAINTENANCE

The solar panel should only be cleaned with soft tissue or propriety glass cleaning solution.

5. TECHNICAL DATA

Solar Panel:	24V-25W
Operation Voltage:	9V-28V DC

6. GUARANTEE

This product is guaranteed for a period of 12 months from the date of purchase for material or manufacturing defects. The guarantee covers the substitution of defective parts. If your pondXpert panel fails please take it back to the retail outlet from where it was purchased. You will be required to take your receipt/proof of purchase with you. This does not affect your statutory rights.

PondXpert
A3 Bentley Avenue
Billingham
TS23 4BU UK
01642 370898
www.pondxpert.co.uk



Your appliance contains valuable materials which can be recovered or recycled. Leave it at a local civic waste collection point.